

NESC 234 CLEARANCES TO OTHER STRUCTURES

Cables 300 V or less need to be a minimum two feet over the street light.



- NESC TABLE 232-1 VERTICAL CLEARANCE OVER SURFACES
- NESC TABLE 235-5 VERTICAL CLEARANCE AT SUPPORTS
- NESC 235C2b(1)(a) SAG RELATED CLEARANCES
- NESC 235H CLEARANCE AND SPACING BETWEEN COMMUNICATIONS

MINIMUM ACCEPTABLE CLEARANCES

NOTE: These values are intended for NESC inspection reference only and are not intended for construction or design criteria.

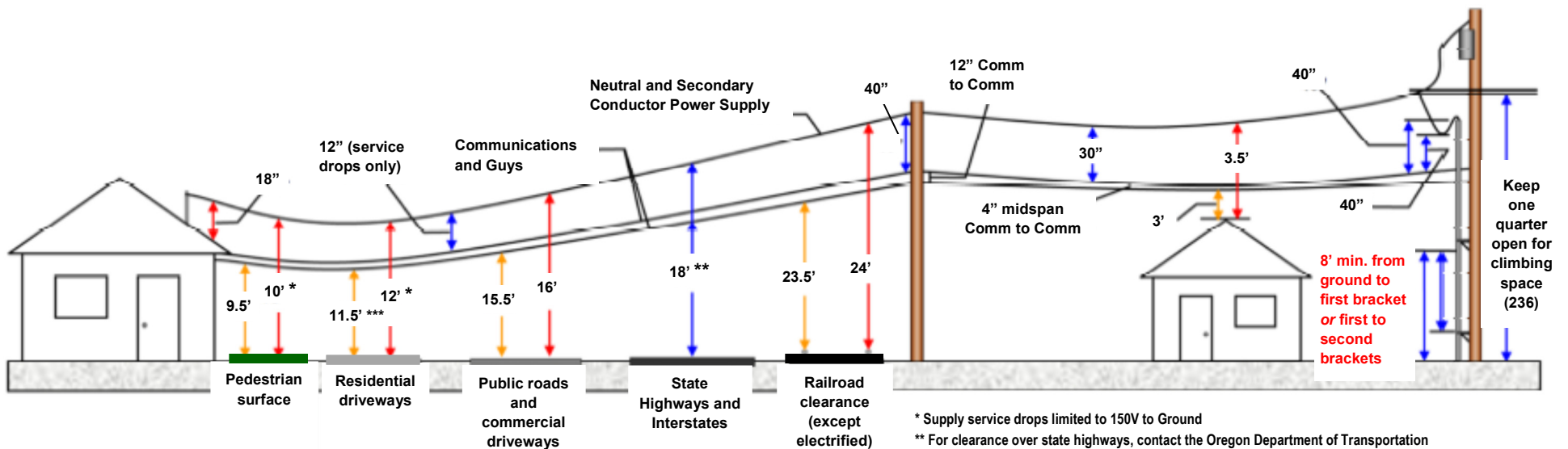

* Supply service drops limited to 150V to Ground

** For clearance over state highways, contact the Oregon Department of Transportation

*** Where vehicles exceeding 8 feet are not normally encountered nor reasonably anticipated

**NESC 236
CLIMBING SPACE**

Climbing Space is an unobstructed, vertical space along the side or corner of the pole. In general, it consists of an imaginary box, 30-inches square, extending at least 40 inches above the highest communications cable or other facility and 40 inches below the lowest communications cable or other facility, but may be shifted from any side or corner to any other side or corner. Support arms are not considered to obstruct the climbing space.

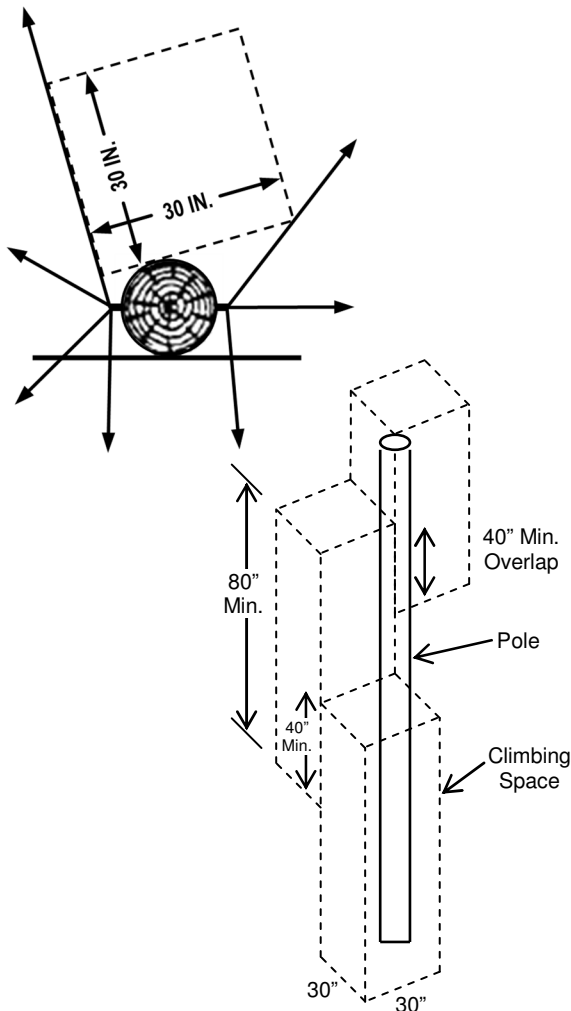

**NESC 238
UNGROUNDING MAST ARMS**

(Assume all streetlights are ungrounded unless ground is visible)

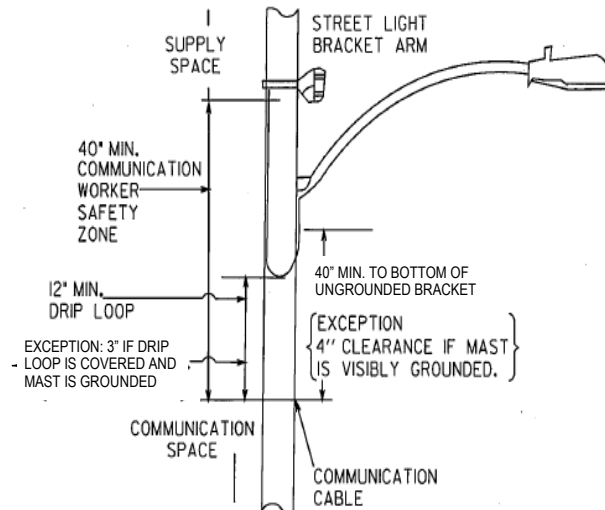

Exception: Maintain clearances of all arms and braces of 20 inches from bonded streetlight. (Not pictured)

**NESC 234C3d(2)
SUPPLY CLEARANCE TO WINDOWS**

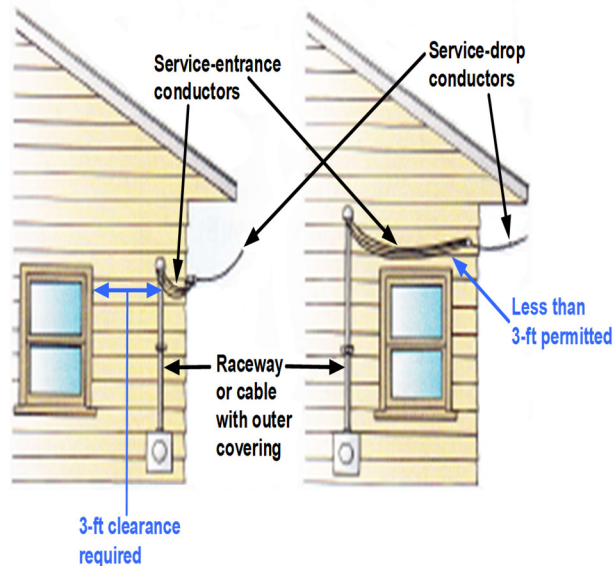

This is not an official codebook. This Document is intended to provide reference for aerial clearances of Communications and Power facilities. When constructing aerial facilities, please refer to the governing codes, such as the National Electrical Safety Code, National Electric Code, Oregon Public Utility Commission Safety Rules, Oregon Occupational Safety and Health Administration, State, County and Municipal codes, and all other applicable company standards, including contracts.

Other Resources:

- OJUA www.ojua.org
- OPUC <https://www.oregon.gov/puc/safety/Pages/SafetyHome.aspx>
- IEEE www.ieee.org/portal/site
- NESC <http://standards.ieee.org/nesc>
- OSHA www.osha.org/admin/safejobsb/sjsbagriculture.html